

Kit 1494

ISUZU D-max Rodeo, 2-dr Single Cab, 02-
CHEVROLET Colorado, 2-dr Single Cab, 04-

480R
754

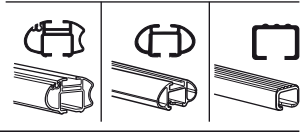
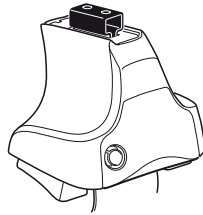

480

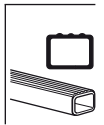
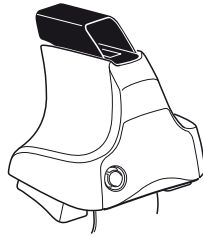

750

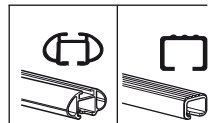
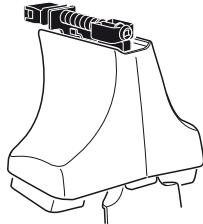

x2	x2	x2	x2	x2
x2		x2	x2	
x2		x4	x2	
x4		x4		

95 x 2
 02 x 2

961 x 2
 65 x 2

x 1

Kit





1

	X
ISUZU D-max Rodeo, 2-dr Single Cab, 02-	34,5
CHEVROLET Colorado, 2-dr Single Cab, 04-	34,5

2

1

	Y
ISUZU D-max Rodeo, 2-dr Single Cab, 02-	38
CHEVROLET Colorado, 2-dr Single Cab, 04-	38

2

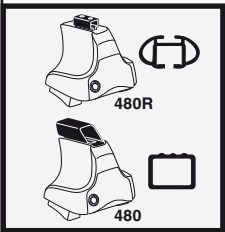

1

	X inch	X mm
ISUZU D-max Rodeo, 2-dr Single Cab, 02-	39 1/4"	996 mm
CHEVROLET Colorado, 2-dr Single Cab, 04-	39 1/4"	996 mm

2

1

	Y inch	Y mm
ISUZU D-max Rodeo, 2-dr Single Cab, 02-	40 5/8"	1031 mm
CHEVROLET Colorado, 2-dr Single Cab, 04-	40 5/8"	1031 mm

2

4

ISUZU D-max Rodeo, 2-dr Single Cab, 02-
CHEVROLET Colorado, 2-dr Single Cab, 04-

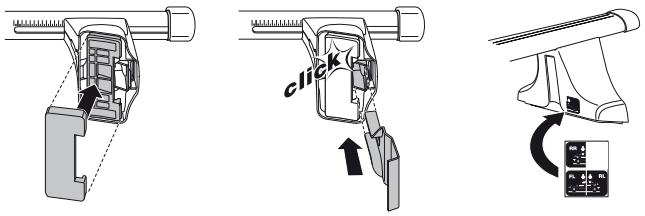
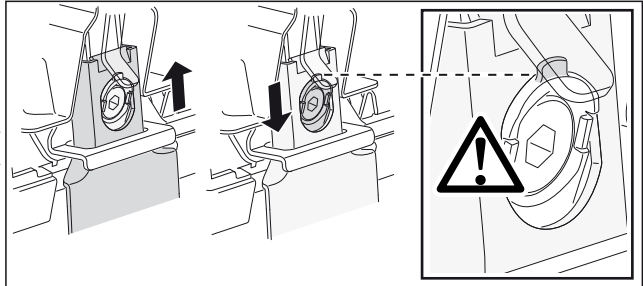
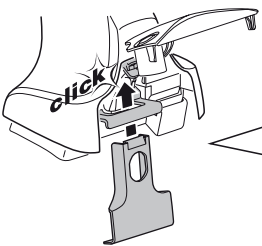
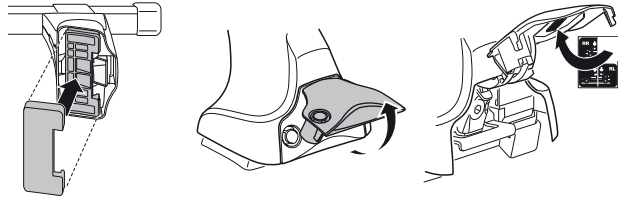
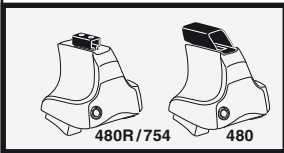
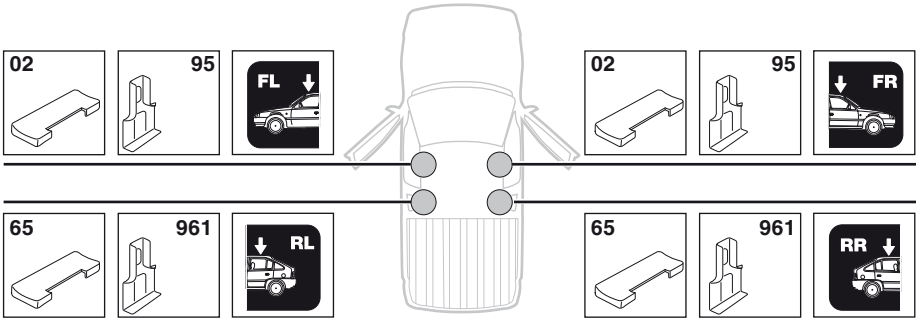

5



	X mm	Y mm	X inch	Y inch
ISUZU D-max Rodeo, 2-dr Single Cab, 02-	285 mm	650 mm	11 1/4"	25 5/8"
CHEVROLET Colorado, 2-dr Single Cab, 04-	285 mm	650 mm	11 1/4"	25 5/8"

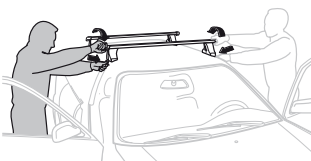
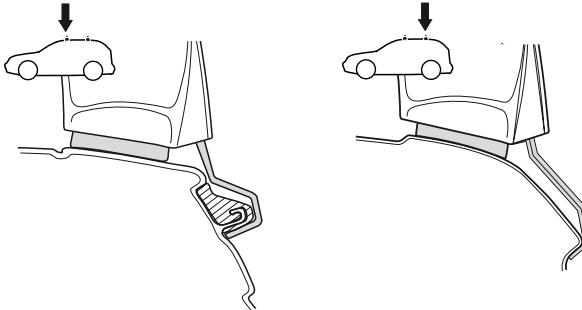
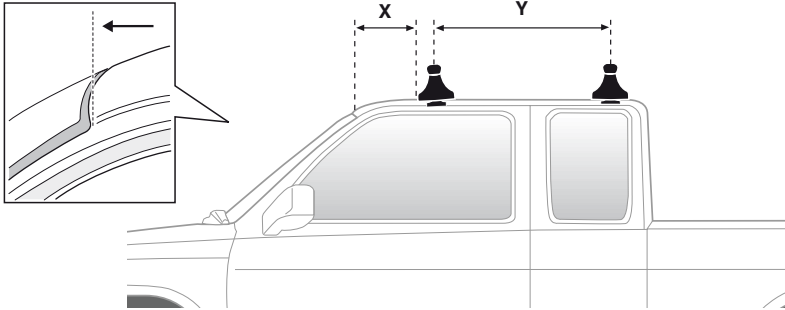

- | | | | |
|--------------|---|------------|--|
| GB/US | Tighten alternately | CZ | Pokreťta bagažníka dokrečaj dokrečaj naprziemiennie. |
| D | Die Schrauben abwechselnd anziehen | SK | Dofahajte striedavo |
| F | Serrer alternativement chaque côté | SLO | Privijajte izmenično. |
| NL | Afwisselend aan de linker- en de rechterkant aandraaien | HR | Naizmjenično zategnite |
| I | Alternare il serraggio delle viti | HU | Egymástól függetlenül szorítandó |
| E | Apretar alternativamente | GR | Σφιγγετε εναλλάξ |
| PT | Aperte alternadamente | TR | Dönüşümlü sıkın |
| S | Dra åt växelvis | 中文 | 交替拧紧 |
| FIN | Kierrä vuorotellen | 한국어 | 변갈아 가며 조이십시오. |
| EST | Pinguldage vaheldumisi | 日本語 | 交互に締め付けてください。 |
| LAT | Pielveiciet pamišus | ไทย | ขันในแบบสลับ |
| LIT | Užsukinėkite pakaitomis | | |
| PL | Śruby dokrećaj naprziemiennie | | |
| RU | Затягивайте попеременно | | |

6



480R/754



480

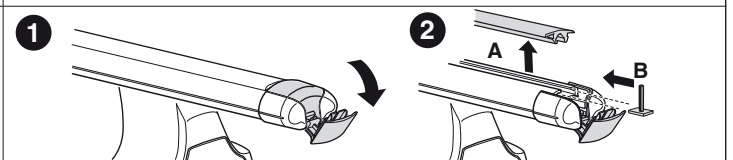
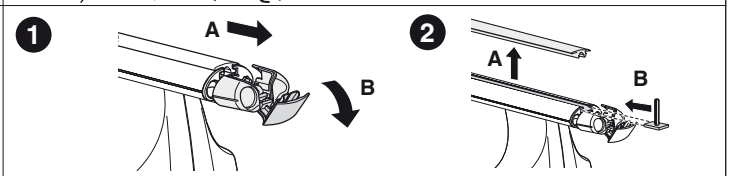
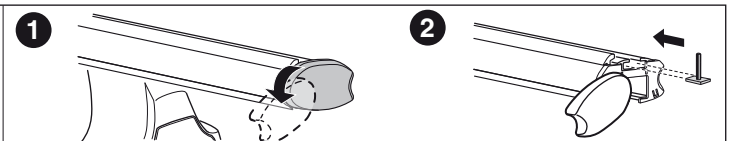
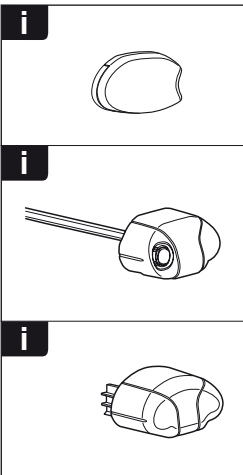
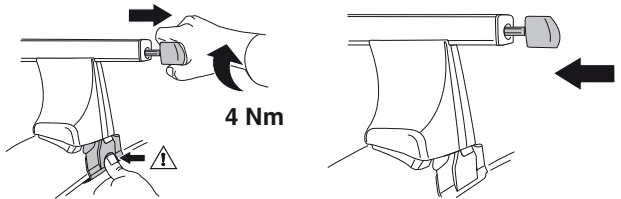
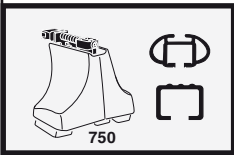

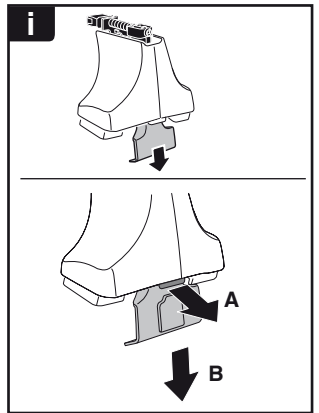
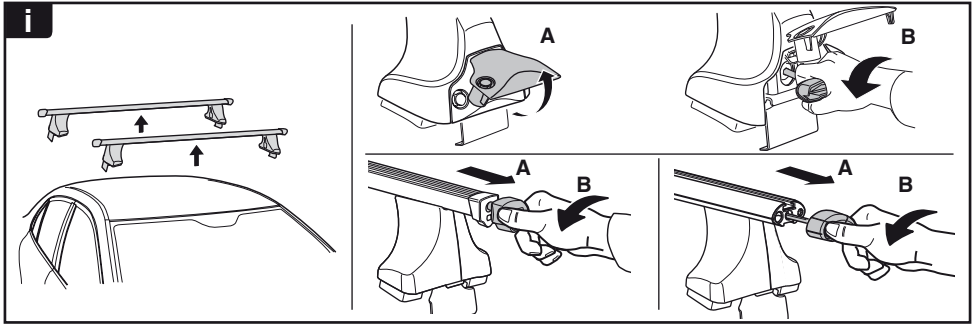

THULE
SWEDEN
**ONE
KEY
SYSTEM**



- 544 (x4)
- 596 (x6)
- 588 (x8)
- NA 510 (x10)
- EUR 452 (x12)
- ASIA



WW ▶ Thule Sweden AB, Box 69, 330 33 Hillerstorp, SWEDEN
NA ▶ Thule Inc., 42 Silvermine Road, Seymour, Connecticut 06483, USA

info@thule.com
customer.service@thule.com

www.thule.com